

Intelligent Sketch-Based Gesture Interface for Android-Controlled Mobile Robot Navigation

Raghab Singh¹, Pramesh Baral²

^{1,2} Department of Computer Science University of South Dakota Vermillion, SD

Abstract - An Android sketch-controlled robotic locomotion system is presented for safe exploration of hazardous environments. The system integrates an Arduino Uno microcontroller, HC-05 Bluetooth module, L293D motor driver, DC motors, and an HC-SR04 ultrasonic sensor. A custom Android application is developed using MIT App Inventor, which converts touchscreen sketches into directional commands that are transmitted wirelessly to the robot. The Arduino microcontroller processes the received commands and actuates the motors accordingly. Obstacle detection is implemented using ultrasonic time-of-flight ranging. The proposed system provides a low-cost teleoperated robotic platform suitable for controlled navigation in constrained and hazardous conditions.

Keywords - Android control, Bluetooth module HC 05, Arduino Uno, ultrasonic sensor HC SR04, mobile robotics

I. INTRODUCTION

Mobile robotic systems are now necessary for situational tasks where human intervention has become unsafe, inefficient, or even inconvenient. Robotic platforms that can be relied on to provide mobility, sensing, and communication are required in applications like disaster response, structural inspection, industrial surveillance, and search-and-rescue operations. Classical robotics literature highlights the importance of perception mechanism, control mechanism, localization mechanism, and actuation mechanism being closely interconnected in order to make a successful mobile system [1], [2]. Although there has been a tremendous improvement in fully autonomous robots, the teleoperated and semi-autonomous systems remain very important in real-life applications owing to less computational load, predictability, and constant human control. The current Android sketch robotic locomotion system is driven by the fact that it is required to have a low-cost, human-in-the-loop exploration robot, with priorities on operational safety and accessibility.

Another key aspect in this project is the human-robot interaction that is easy to use. The interfaces used in traditional forms of teleoperation are based on discrete button presses, joystick controls, which may limit intuitive interaction compared with trajectory-based gesture control approaches [3]. Such interfaces are also functional, but have cognitive overhead and limitations on natural trajectory expression. The HRI field of research points out that the interface design plays a significant role in decreasing the workload of operators and enhancing the performance of the task [4]. Gesture interaction in a touchscreen can provide a viable alternative since the use of smartphones is ubiquitous. Android devices consist of wireless communication, processing, and high-resolution input interfaces, which are integrated. Previous investigations have also confirmed the practicability of Android-managed mobile robots on Bluetooth communication-based surveillance and surveillance applications [5], [6]. Nevertheless, directional control is an elementary mechanism that is in place on most of the systems. The suggested system goes as far as to add to this idea by having a sketch input that enables user-drawn motion patterns to be translated into locomotion commands, which enhances the efficacy of teleoperation.

The other need is high-quality short-range wireless communications. Introduced in the 2.4 GHz portion of the ISM band, Bluetooth technology has low power consumption, is easy to pair, and has sufficient speed of data transfer in commands. In the case of embedded robotic platforms, HC-05 can be used, which supports serial communication via UART that is compatible with microcontrollers. Indoor robotic systems based on Bluetooth control architectures have been tested as being practical [5], [6]. Bluetooth has lower power needs and eases the integration of systems, so it is appropriate in applications where prototyping educational exploration tasks are controlled, and a Wi-Fi connection is difficult to achieve. Since the suggested robot is aimed at short-range risky scenarios like confined buildings, Bluetooth interconnection is appropriate in terms of operational features.

Another important project requirement is safe navigation. Obstacle detection is also important even in teleoperated systems, to avoid unwanted collisions and mechanical damage. Mobile robotics has a wide range of perception systems, starting with simple proximity sensors, LiDARs, and vision-based systems [2]. Ultrasonic time of flight sensing is a commonly used, cost-effective method of measuring short-range distances. The ultrasonic ranging theoretical framework of computing the distance by the time the echo returned is developed in the field of robotics [1]. Although existence of more resolution sensing modalities, the ultrasonic sensors offer an acceptable level of precision and power with regards to indoor navigation.

The necessary environmental awareness can be achieved by the use of HC-SR04 sensor in the proposed system with minimum complexity added to the calculations.

Embedded control architecture is another requirement. Microcontroller-based platforms have been extensively used in prototyping robots due to deterministic timing, low power consumption and also have the capability of interfacing with other modules [2]. Arduino Uno is a platform based on ATmega328P, and it is capable of managing digital I/O, analog input, and memory resources, thus performing serial communication, motor control programs, and sensor interfacing. Two independently controlled DC motors and an H-bridge motor driver, such as the L293D, have been shown to constitute a differential drive locomotion, one of the most mechanically efficient and most commonly studied mobility configurations in wheeled robotics [1]. This structure guarantees flexibility and mechanical ease, which matches the cost-based and educational aims of the project.

In addition to deterministic teleoperation, the current study of robotics applies more methods of adaptive learning and evolutionary optimization to improve the robustness in dynamic settings. Robots can build and optimize control policies by trial and error with their environment using reinforcement learning structures, which are useful in reducing performance indicators, including stability and task completion performance [3]. On the same note, evolutionary AI methods search morphological and locomotor design evolution in robust exploration robots [7]. Even though the current system does not adopt learning-based autonomy, the previous research demonstrates the larger research environment in which teleoperated platforms can become intelligent adaptive systems. The designed architecture can thus be used as a platform on which adaptive control strategies can be attached in the future.

II. BACKGROUND AND RELATED WORK

A. Foundation of Mobile Robot Locomotion

The problem of mobile robot locomotion has been widely researched in terms of kinematic modelling, motion planning, and control stability. One of the most commonly used architectures in mobile robots is the differential drive mechanisms where two independently actuated wheels are used; the reason being the simplicity and maneuverability of the design. Such nonholonomic systems have good kinematic and control schemes [8], [9]. To be more precise, the laws of stabilization of posture of the wheeled mobile robots and the laws of the trajectory tracking control have been analyzed critically to enable the wheeled mobile robots to be stable in terms of navigation within a limited speed range [8]. Moreover, the questionnaires concerning the use of motion control techniques identified the tradeoff between implementation and performance in environmental perturbations [9]. The present project includes a differentiable drive scheme, which fits within these existing frameworks, but is concerned with controllability and mechanical simplicity in indoor exploratory tasks. Teleoperation and Human Robot Interaction.

B. Teleoperation and Human Robot Interaction

Robotic systems that are teleoperated are essential in environments that are hazardous or uncertain, where full autonomy is not dependable. The studies conducted in the context of human-robot interaction (HRI) have highlighted interface transparency, less cognitive load, and natural mapping of commands as the primary factors that influence the efficiency of teleoperations. The initial experimental reviews of teleoperation interfaces have indicated that control modality and feedback design have a strong influence on operator performance [10]. Moreover, research on human supervisory control over robots has shown that simplified interaction models enhance reaction time and situational awareness in the process of navigation [11]. This evidence confirms that alternative paradigms of interaction other than the conventional input mechanical joystick are necessary. When used within the framework of this project, gesture control using sketches will seek to bring the commands to the robot motion closer to the human motor intuition.

C. Wireless Communication in Embedded Robotic Systems

Wireless communication technologies play a central role in distributed robotic architectures. Performance evaluations of Bluetooth-based embedded communication confirm stable serial data exchange under moderate interference conditions [12]. Since the suggested robot will be used in short-range hazardous exploration and not long-range deployment, the Bluetooth communication can meet the energy and integration needs.

D. Obstacle Detection and Proximity Sensing

The mobile robots require environmental perception as a major requirement. Whereas sophisticated systems use LiDAR and vision-based simultaneous localization and mapping (SLAM), low-priced platforms often make use of ultrasonic proximity sensing. The results of experimental investigations of ultrasonic sensors indicate that they can be used with acceptable accuracy when detecting obstacles over a short distance within structured indoor environments [13]. The ultrasonic ranging time-of-flight principle is computationally cheap and capable of integration into a microcontroller processor. Even though ultrasonic sensors cannot be used to map out in detail, it has enough collision avoidance to be used in teleoperated systems. The implementation of sensing based on HC-SR04 in this project is consistent with the proven low-cost robotic design processes.

III. METHODOLOGY

A. System Architecture and Component Integration

The Android Sketch Controlled Robot Locomotion is modeled such that the hardware integrated into the unit, communication, sensing, and control software create the ability to make a robotic vehicle follow directional sketches drawn by a mobile device. The architecture of the robot comprises an Arduino Uno microcontroller, HC-05 Bluetooth, L293D motor driver IC, two DC motors to act as locomotors, and an HC-SR04 ultrasonic sensor to detect obstacles. The Android device will act as a command interface with sketches of direction sent via the Bluetooth connection to the Arduino, which then deciphers the message and sends the motors into motion.

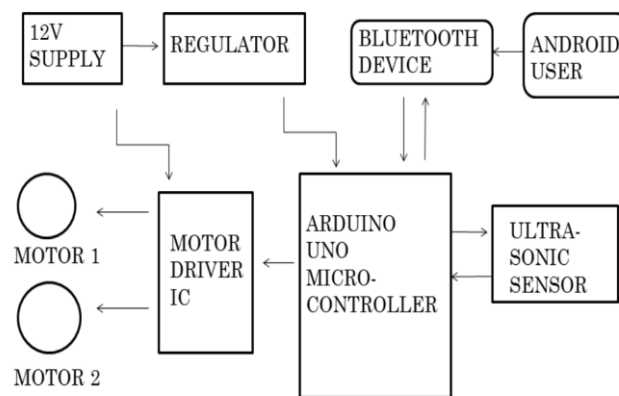

Figure 1: Architecture of the Robot

The Bluetooth HC-05 module allows the mobile device and robot to communicate wirelessly through a serial connection. This module works in master-slave mode, and there are cross-connections between the Tx/Rx pins of the module and Rx/Tx pins of the Arduino to guarantee a high level of data integrity. Directional commands coded in the Android application are sent via Bluetooth and are used to control the movement of the robots in real-time.

B. Hardware Interfacing

The locomotion system of the robot is placed by the connection between the Arduino Uno and the L293D motor driver IC. The L293D IC can be used to control two DC motors in a bidirectional way, and the rotation direction depends on the input signals of the Arduino. The DC motors to the output pins of the IC give it forward, backward, left, and right motion. The HC-SR04 ultrasonic sensor is connected to the Arduino in terms of trigger and echo pins to carry out non-contact distance measurement so that obstacles can be detected in a range of 2 cm to 400 cm.

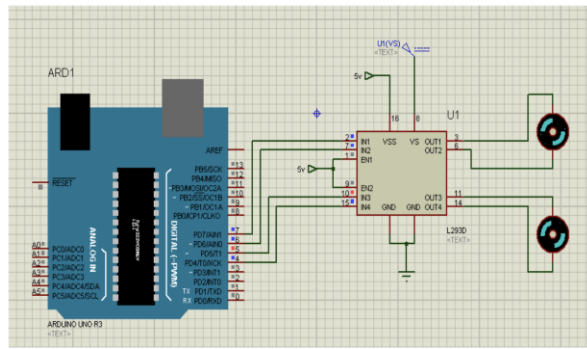

Figure 2: Motor Arduino Interfacing

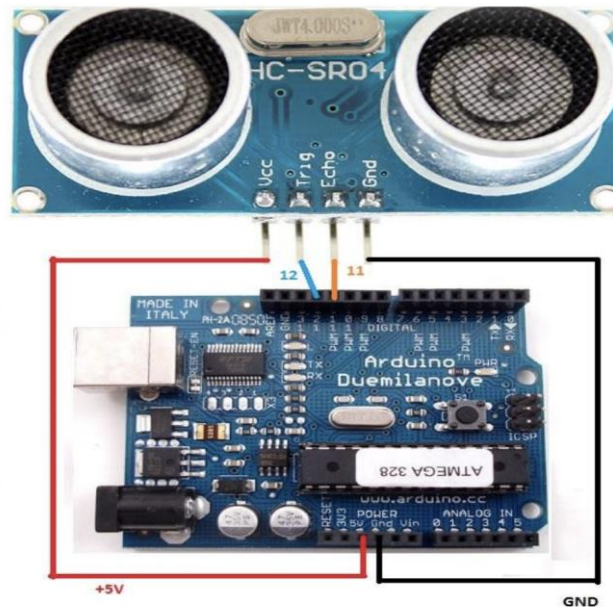

Figure 3: Ultrasonic Sensor Interfacing

C. Android Application Development

The Android application is created with the help of MIT App Inventor, which provides a graphical representation of sketching direction and sends the necessary commands to the robot [14], enabling a trajectory-based interaction similar to gesture-driven control interfaces used in human-robot interaction systems. The interface contains directional controls, a speed slider, and Bluetooth device selection through a list picker. Sketch input is translated to serial commands, which are used to activate robot movement. Continuous communication and command updates are done by clock logic and control blocks.

D. Control Software Implementation

The control logic is implemented in C/C++ in the Arduino IDE. The setup procedure allows the configuration of communication interfaces, pins, and sensor settings, and consequently, the loop () procedure constantly processes incoming Bluetooth commands. Directional inputs create the motor control signals, and the ultrasonic sensor takes the periodic

distance readings so that there is no collision. The system works in a closed-loop approach where motion commands and the obstacle detector are worked out continuously to support proper navigation.

IV. RESULTS

The system is able to read the drawing on Android to command the movement of the robot in the four major directions: forward, backward, right, and left. The DC motors are sensitive to the control signals, confirming proper operation of the motor drivers and command execution.

The HC-SR04 ultrasonic sensor has a high accuracy and can measure distances ranging between 2 cm and 400 cm, making it useful in obstacle detection in order to navigate safely. The sensor is capable of giving effective readings in any ambient lighting conditions.

The Android application creates a stable Bluetooth connection with the robot and sends directional commands with a minimal delay. By sketching drawings, users are able to control the robot, based on drawings to navigate it, control its speed, and other options like camera rotation. The application interface makes it easy for operators to control even without prior technical knowledge.

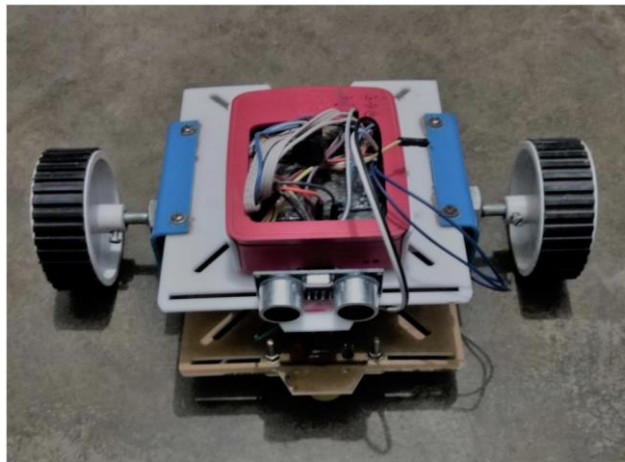

Figure 4: Android Sketch Controlled Robot

V. DISCUSSION

The Bluetooth communication, Android interface, and Arduino-based hardware integration offer a proper solution to the real-time control of the robot. The draw-based navigation system increases the simplicity of work, and the robot can be controlled with respect to its position accurately without using a manual joystick or a complicated control board.

This motor driver IC and DC motor combination enables bidirectional locomotion, which shows the same and repeatable movement in all directions called on. The ultrasonic sensor provides the ability to detect obstacles and provide contingent awareness, but only the detection and the logging of commands were possible.

The use of Bluetooth communication is an effective medium for transmitting commands inside the building. The system exhibits a high reactivity to sketch input, but Bluetooth restricts its operation range. The implementation in the future can have Wi-Fi or Zigbee modules to increase the distance of the control without losing the flexibility of the system.

The whole hardware-software structure attains the objective of Android sketch-based locomotion and simple environmental perception. The modular design also supports future development, such as adding GPS, gas sensors, or automated navigation algorithms, without altering the architectural structure that is already developed in the present implementation.

VI. KEY FINDINGS

The project demonstrates that sketch-based control offers an interactive means of movement control of the robot, even without technical knowledge. Hardware and software can be readily combined in a modular way, which allows future upgrades. Dynamic environments enhance operational safety because of real-time user input. The fact that low-cost components are used proves that it is possible to create a good robotic system at a low cost. All in all, the interface can be used to enable more sophisticated semi-autonomous or adaptive robotic tasks.

VII. FUTURE ENHANCEMENTS

In future work, the proposed sketch-controlled robot system can be enhanced by integrating artificial intelligence techniques to improve gesture recognition and enable more intelligent robot control. Machine learning and deep learning models could allow the robot to interpret complex sketch-based commands, while AI-based perception and decision-making modules may support autonomous navigation, obstacle avoidance, and adaptive motion planning. Additionally, incorporating wireless technologies such as Wi-Fi or Zigbee can extend operational range, while integrating GPS and environmental sensors (e.g., gas, temperature, and obstacle detection) can improve situational awareness, similar to IoT-based monitoring architectures used in sensor network systems [15]. Further improvements such as component miniaturization and the addition of advanced modules like RFID-based security or specialized tools could expand the robot's applications in safety, surveillance, and industrial environments.

VIII. REFERENCES

- [1] S. R. I. R. Nourbakhsh and D. Scaramuzza, *Introduction to autonomous mobile robots*, MIT press, 2011.
- [2] S. B. O. Khatib, T. Kröger and e. , Springer handbook of robotics, Berlin: springer, 2008.
- [3] R. Singh, "Reinforcement learning for robotic singulation: Policy space impact on interactive manipulation," in *International Conference on Future Technologies (ICFT)*, 2025.
- [4] C. J. YC, E. C, H. and M. J. Barnes, "Human performance issues and user interface design for teleoperated robots," in *IEEE Transactions on Systems, Man, and Cybernetics, Part C (Applications and Reviews)*, 2007.
- [5] J. T. Maria, P. T. Vasumathi , R. Lavanya and S. R. Pandian, "Mobile robot temperature monitoring system controlled by Android application via Bluetooth," *International Journal on Advanced Computer Theory and Engineering (IJACTE)*, vol. 2, no. 3, pp. 138-142, 2013.
- [6] B. K. R. Gaikwad and A. Rajput, "Wireless controlled surveillance robot," *International Journal of Advance Research in Computer Science and Management Studies* , vol. 2, no. 2, pp. 436-437, 2014.
- [7] R. Singh, "Evolutionary AI for Morphological and Locomotor Design of Resilient Exploration Robots," in *9th International Conference on Computational System and Information Technology for Sustainable Solutions (CSITSS)*, 2025.
- [8] S. C, *Control of chained systems application to path following and time-varying point-stabilization of mobile robots*, vol. 40, IEEE transactions on Automatic Control, 2002, pp. 64-77.
- [9] K. Y. Y. Kimura, F. Miyazaki and T. Noguchi, "A stable tracking control method for an autonomous mobile robot," in *In Proceedings., IEEE International Conference on Robotics and Automation*, 1990.
- [10] S. and T. , "Human supervisory control of robot systems," in *IEEE International Conference on Robotics and Automation*, 1986.
- [11] G. M. A and A. C. Schultz, *Human-robot interaction: a survey*, 2008.

- [12] B. and J. , *A Proposed Framework for Crowd-Sourced Social Network Data Collected over Bluetooth*, 2014.
- [13] B. J. and Y. Koren, "Obstacle avoidance with ultrasonic sensors," *IEEE Journal on Robotics and Automation* , vol. 4, no. 2, pp. 213-218, 2002.
- [14] R. Singh, "Gesture Recognition for Remote Control Systems Using Kernel Principal Component Analysis (KPCA) and Trajectory Normalization," in *TechRxiv*, 2025.
- [15] K. Khanal, G. Ojha, S. Chataut and U. K. Ghimire, "IoT-Based Real-Time Soil Health Monitoring System for Precision Agriculture," in *International Research Journal of Engineering and Technology (IRJET)*, 2024.